

## Installation instruction for Solar Photovoltaic Modules

### **IMPORTANT INFORMATION!**

**These installation instructions should be read carefully before beginning any work on the installation, operation and servicing of the PV system. Failure to do so can lead to injury to persons and damage to property. National electrical installation codes and regulations should be referred to and observed at all times. A copy of these instructions should be included in the system documentation.**

**Installing a PV system requires specialist knowledge, especially the installation and wiring of the modules. It should only be carried out by suitably qualified and authorized persons. Children should not be allowed near the installation while work is being carried out.**

### **General safety information**

The solar modules should only be used for the purposes for which they are intended, see Module installation.

All work on the PV system, i.e. installation, commissioning, servicing and repairs, should be carried out by qualified and authorized persons.

During installation all local and national electrical and building codes and regulations, health and safety regulations, and accident-prevention regulations should be strictly observed. The safety instructions for all system components should be followed.

Artificially concentrated sunlight shall not be directed on the solar module.

### **Before beginning work**



All protective measures regarding working at heights and preventing falls specified in national and local health and safety codes and regulations should be implemented before and during all work on roof-mounted and other PV array structures, and all necessary scaffolding and other protective measures applied at the site of the installation. Protective helmets, gloves and footwear should be worn during installation work. Protective goggles should be worn when carrying out drilling, cutting or grinding work. Safety harnesses may be required in some situations.

### **Working with DC electricity**



Short circuits on the DC side of the installation can cause arcing. This is a fire hazard. Unlike arcs occurring in conventional low voltage AC wiring, these arcs are not self-extinguishing.

The high temperatures generated by these arcs can destroy contacts and connectors. If not handled and installed according to instructions, solar modules can present a lethal hazard.

### **Fire safety**



The following points need to be observed when installing the modules:

- Refer to your local authority for guidelines and requirements for buildings or structural fire safety.
- The roof construction and installation may affect the fire safety of a building. Improper installation may contribute to hazards in the event of fire.
- It may be necessary to use components such as earth ground fault circuit breakers and fuses.

### **Warning notices**

#### **Danger of death from electric shock**



Solar modules generate electricity and produce a voltage when exposed to light. The voltage produced by one module is below the safety extra low voltage (SELV) level. However, when modules are connected in series (voltages are added together) or in parallel (currents are added together), this can give rise to voltage and currents which can present a danger. While, the fully insulated plug contacts provide touch protection, the following points need to be observed when handling the modules in order to avoid the risk of sparking, i.e. fire hazard, and lethal electric shocks.

- No electrically conducting parts should be inserted into the plugs or sockets.
- Solar modules and wiring should not be fitted with wet plugs or sockets. Materials, tools and working conditions need to be dry.
- The utmost caution should be exercised when wiring the modules and the work should be carried out using appropriate safety equipment, i.e. insulated tools, insulated gloves, etc.
- Damaged modules should not be used. Modules should not be disassembled.
- No paints, adhesives or detergents should be applied to the back of the laminate. Do not mark the module using sharp or pointed objects.

## Danger of death from arcing



Solar modules generate direct current (DC) when exposed to light. Breaking or opening a connection under load, i.e. when current is flowing, can give rise to an electric arc which will not self-extinguish. It is therefore recommended that the modules are covered with a non-transparent cover during installation work. Opening or breaking the connection on a string of modules in which current is flowing, e.g. disconnecting a DC cable from the inverter while it is under load/connected to the grid, can give rise to a lethal electrical arc. An inverter can produce high voltages even when disconnected.

- The solar array (generator) should never be disconnected from the inverter while the inverter is connected to the public grid. The inverter AC fuse/circuit breaker should first be removed/opened in order to disconnect the inverter from the grid.
- When an inverter is switched off/disconnected, it is necessary to wait for the time specified by the manufacturer before working on it. Its high voltage components need sufficient time to discharge.
- Module wiring should be carefully carried out. Beware of damaged cable ends, split cable ends, dirt, etc.
- The inverter manufacturer's installation, handling and operating instructions should be followed at all times.

## Unpacking and storing the modules

Warnings and instructions on the packaging should be observed. A record of the module serial numbers should be made before installation and this should be included in the system documentation. If it is necessary to put the modules into temporary storage, they should be kept in dry and properly ventilated room.

Modules should be handled with care. The following points need to be observed when the modules are being unpacked, transported or stored:

- Modules should be carried using both hands, the junction box should NOT be used as a grip.
- Modules should not be allowed to sag or bow under their own weight when being carried.
- Modules should not be subjected to loads/stresses and should not be stood upon or dropped.
- All electrical contacts should be kept clean and dry.

## Module installation

"The module is considered to be in compliance with UL 1703 only when the module is mounted in the manner specified by the mounting instructions below."

### Maximum permitted module loadings/stresses

The maximum load the module should be subjected to must not exceed 5.4 kN/m<sup>2</sup>. Site-specific loads such as wind and snow need to be taken into consideration to ensure that this is not exceeded.

## Equipotential bonding of modules and module frames

The equipotential bonding and its integrity must be carried out, approved and verified by a qualified electrician. National electrical codes and regulations should be referred to before undertaking any grounding work.

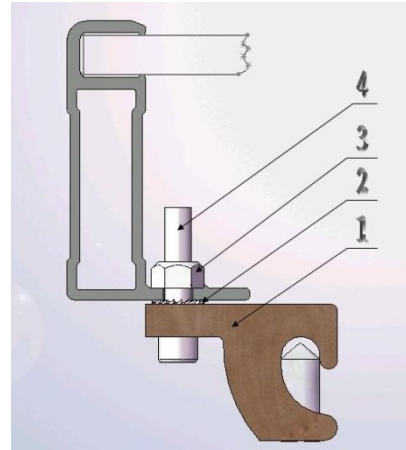

Illustration 1

It is recommended that the equipotential bonding is being carried out as shown in illustration 1, i.e. with a grounding lug, star washer (M4), nut (M4) and a screw (M4) shown as "1", "2", "3" and "4" in illustration 1. The existing grounding holes should be used.

If a module is connected by a conducting connection to a mounting structure, the module itself does not have to be grounded as long as the mounting structure is properly grounded by a qualified electrician.

### U.S. and Canada only:

"A module with exposed conductive parts is considered to be in compliance with UL 1703 only when it is electrically grounded in accordance with the instructions presented below and the requirements of the National electrical Code."

Where common grounding hardware (nuts, bolts, star washers, spilt-ring lock washers, flat washers and the like) is used to attach a listed grounding/bonding device, the attachment must be made in conformance with the grounding device manufacturer's instructions.

Common hardware items such as nuts, bolts, star washers, lock washers and the like have not been evaluated for electrical conductivity or for use as a grounding devices and should be used only for maintaining mechanical connections and holding electrical grounding devices in the proper position for electrical conductivity. Such devices, where supplied with the module and evaluated through the requirement in UL 1703, may be used for grounding connections in accordance with the instructions provided with the module

All PV modules must be grounded by electrical connection from the module frames to ground. The existing grounding holes in the module frames should be used. An UL-listed grounding lug must be used, e.g. CL50DBTN (Solar panel copper lay-in grounding lug, tin plated, 14-4 AWG, stainless steel screw) available from [www.elecDirect.com](http://www.elecDirect.com).

To ensure a conductive connection, i.e. to penetrate the nonconductive coating on the frame, a combination of screw, star washer and lock nut must be used to mount the grounding lug onto the frame. The star washer must be placed between the frame and the grounding lug.

## Hazardous locations and environmental factors

The modules are designed to be installed in moderate/temperate climatic conditions. The modules are not suitable for installation in potentially explosive or flammable environments

If the modules are mounted on a roof top, the modules are to be mounted over a fire resistant roof covering rated for this type of application.

In cases where there is a potential risk of snow loads and/or snow slides, countermeasures has to be taken to ensure that module frames on lower roof edges cannot be bent or displaced.

The modules should not be installed at the following locations:

- Nearby sources of flammable gases and vapors, e.g. gas/petrol stations, gas storage containers, spray paint facilities.
- Nearby naked flames or flammable material.
- Under water or in a fountain or other similar water feature.
- Where they are exposed to artificial light.
- Where they are exposed to salt, recommended distance from the sea: 500m,
- Where they are exposed to sulfur, e.g. near sulfur springs or volcanoes, because of the danger of corrosion.
- Where they can be exposed to unusual/exceptional chemicals, e.g. emissions from chemical works.
- Any module without a frame (laminate) shall not be considered to comply with the requirements of UL 1703 unless the module is mounted with hardware that has been tested and evaluated with the module under this standard or by a field inspection certifying that the installed module complies with the requirements of UL 1703.

## System electrical and technical specifications

The modules should only be used in systems where they meet the specific technical requirements of the system as a whole. Ensure that other system components will not cause mechanical or electrical damage to the modules.

If the modules are to be connected together in series they should have the same amperage. If they are to be connected in parallel they should have the same voltage. String configuration should be planned and carried out in accordance with inverter manufacturer's instructions. The number of modules connected to an inverter should be within the inverter voltage limits/operating range and the design of the string configuration(s) should comply with the inverter's manufacturer's guidelines. The modules should not be configured in such way that they create a voltage higher than the permitted system voltage. National electrical codes and regulations need to be referred to.

For cable wiring recommended cable area is minimum 4 mm<sup>2</sup> (minimum AWG 11)

The type of conductor (cable for wiring) shall be of a type designed for solar energy application, e.g. Multi-Contact Solar cable Flex-Sol or equivalent. Temperature range shall be at least -40 to +90°C and the cable shall be UV resistant.

## Application class

The modules are qualified for application class A: Hazardous voltage (IEC 61730: higher than 50V DC; EN 61730: higher than 120V), hazardous power applications (higher than 240W) where general contact access is anticipated (modules qualified for safety through EN IEC 61730-1 and -2 within this application class are considered to meet the requirements for Safety Class II)"

## Mounting specifications

These modules are not suitable for installation as overhead or vertical glazing, e.g. on facades.

The array mounting structure should be able to withstand anticipated wind and snow loads. At the bottom of the module frames there are openings which allow rain water to flow away. NB! Do not cover the corner draining holes shown in illustration 2 below.

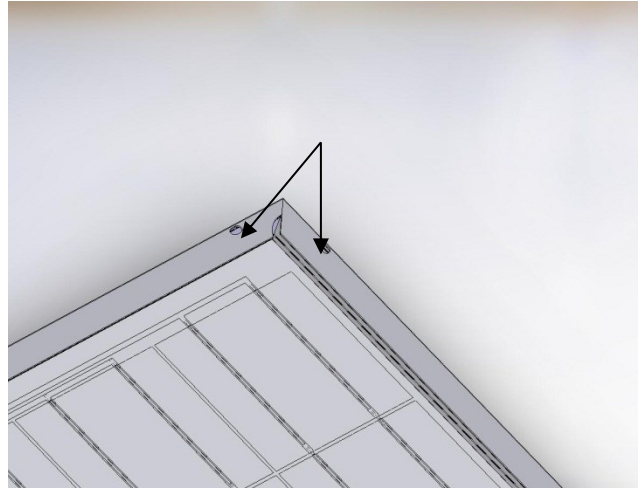

Illustration 2

## Optimum orientation and tilt

To maximize system output the modules should be installed at optimum orientation and tilt angles. This will depend on location and needs to be ascertained by the system designer. The ideal angle is when the sun's rays are perpendicular to the module surface. In any one string, all the modules should have the same orientation and tilt in order to avoid under-performance due to mismatching.

## Shade and shadows

Even small and partial shading of the modules/array, e.g. caused by dirt accumulation, will cause reduced output. A module is considered shade-free when it is free from shade or shadows all year round and is exposed to several hours of sunlight even during the most unfavorable days.

## Fastening the modules to the mounting structure

Each module must be securely fixed to the mounting structure at minimum four points. The long sides of the module frame have been stress tested and are to be used for fixing the modules to the mounting structure, see illustration 3. The short sides of the modules should not be used for this purpose, see illustration 4.

The mounting structure rails are shown in green. To avoid stress to the frame corners of the module, each mounting rail shall cross both long side frames, see illustration 3.

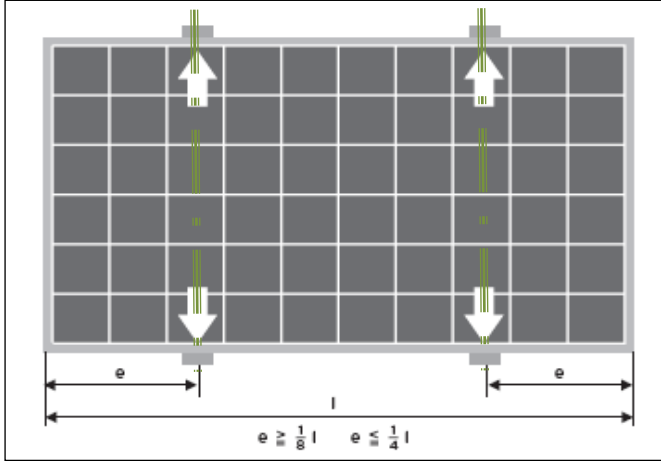

Illustration 3

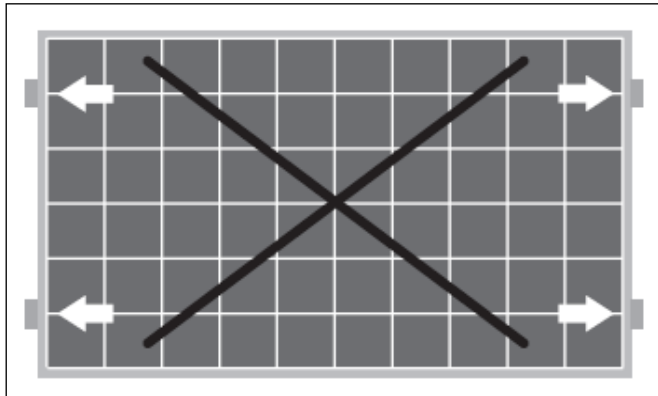

Illustration 4

## Galvanic corrosion

To avoid galvanic corrosion, sometimes called dissimilar metal corrosion, use only fastening materials that are galvanized or hot dip zinc plated. Do not use high value materials as for example corrosion resistant materials that have chromium in them or other alloys with high value materials.

## Fixing the modules to an array mounting structure

### Option 1

Clamps see illustration 5. NB! Additional equipotential bonding is required.

### Option 2

Nuts and bolts see illustration 6. Serrated lock nuts should be used. Additional equipotential bonding is required for the metal support structure. A torque wrench should be used to tighten nuts and bolts. The applied torque required when using V2A M6bolts, as shown in illustration 6, must be within a range of 8-12Nm. The existing holes in the frame should be used. NB! The warranty will be nullified if additional holes are made in the frame. All fixing and fastening materials should be corrosion resistant.

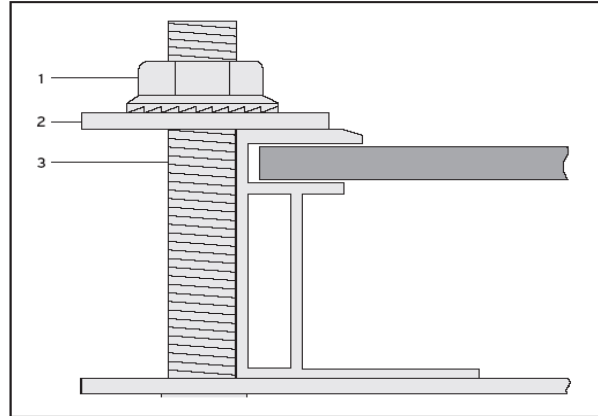

Illustration 5

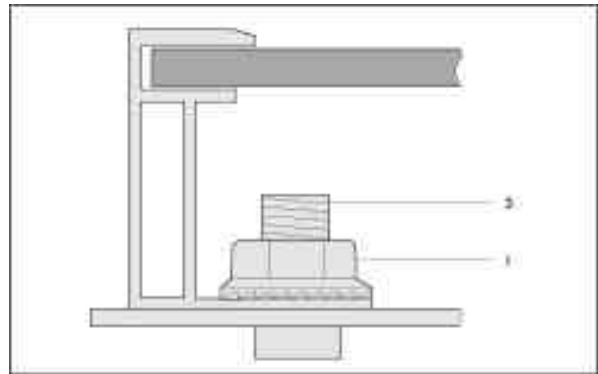

Illustration 6

## Option 3

Windon ground mounting structure, exclusively designed for a very fast installation of Mbili, Tatu and Moja module types, see illustration 7-9.

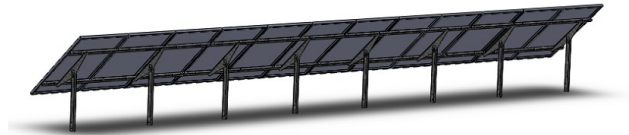

Illustration 7

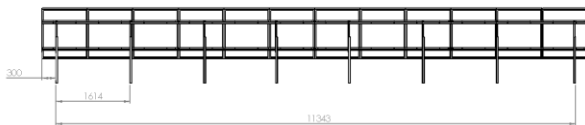

Illustration 8

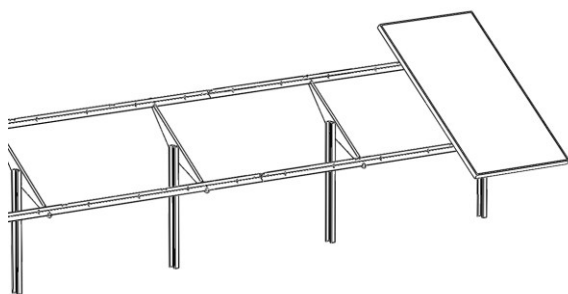

Illustration 9

To prevent rust, all steel rails and poles are hot dip galvanized and powder coated.

A number of poles are piled down with an earth auger or for larger installation with a pile driver.

For detailed assembly instructions please see installation manual for Windon ground mounting system at [www.windon.se](http://www.windon.se)

## Wiring

### Wiring layout and configuration

In order to minimize voltage surges which could be induced by indirect lightning strikes, DC cables of the same string should be bundled together so that loops are kept as small as possible. String configurations should be checked before system commissioning. If the open circuit voltage,  $V_{oc}$ , and the short circuit current,  $I_{sc}$ , deviates from the specifications, this could indicate a configuration fault. Correct DC polarity should be observed at all times.



### Connection of plug connectors

All connections should be secure and tight and electrically and mechanically sound. The modules can be delivered with MC3 (illustration 7) or MC4/KSK4 (illustration 8) type of connectors.

#### Minus



Illustration 7

#### Plus

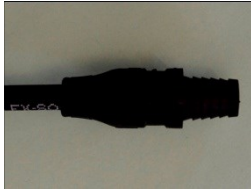

#### Minus



Illustration 8

#### Plus



### Accessories and materials

UV-resistant cables and connectors approved for outside use shall be used. Ensure that they are electrically and mechanically sound. Cable cross sectional diameters shall be chosen so as to ensure that DC power losses (voltage drop) is less than 1%. National electrical codes and regulations need to be referred to when selecting cables. For field connections, use minimum 4 mm<sup>2</sup> or no.11 AWG copper wires insulated for a minimum of 90°C.

### Protecting the cables

Cables should be secured to the array mounting system using UV-resistant cable ties. Loose and unsecured cables should be protected from mechanical damage (laid in plastic conduit or pipes). Avoid, as far as possible, exposing the cables to direct sunlight.

### Grounding

Module frames should be connected to an earth ground. See Module installation for further information.

## Module ratings

### Temperature ratings (measured at TÜV, April 2013)

Nominal operation cell temperature (NOCT):	47,5	(°C)
Temperature coefficient of P <sub>mpp</sub> :	-0,535	(% / K)
Temperature coefficient of V <sub>oc</sub> :	-0,387	(% / K)
Temperature coefficient of I <sub>sc</sub> :	0,037	(% / K)
Temperature coefficient of I <sub>mp</sub> :	-0,046	(% / K)

## Fire rating

Class C

The fire rating of this module is valid only when mounted in the manner specified in the mechanical mounting instructions, see section "Module Installation."

## Electrical ratings

Series resistance of module 305 (mΩ)

## Electrical characteristics

### General module characteristics:

Number of cells: 60
Bypass diode rating: 2x15A in each diode package.
Bypass diode rating for junction box: 10A
Number of diodes: 3
Rated surge voltage (junction box): 8000V
IEC rated system voltage: 1000V maximum
UL rated system voltage: 600V maximum
Over current protection rating: 20A
Temperature rating of cables: -40°C...90°C
Maximum module in series configuration: 21
Modules in parallel configuration: 1

### Values at Sandard Test Conditions:

Irradiance level 1000W/m<sup>2</sup>, Cell temperature 25°C, spectrum AM 1,5.

Module type	M bili Tatu Moja							
	Multi-crystalline cells				Mono-crystalline cells			
Electrical data								
Nominal power (P <sub>mpp</sub> )	240	245	250	255	260	265	270	275
Power sorting from nominal (Wp)	0-5	0-5	0-5	0-5	0-5	0-5	0-5	0-5
Maximum pover voltage V <sub>mpp</sub> (V)	29,8	30,0	30,3	30,6	30,9	31,2	31,5	31,8
Maximum pover current I <sub>mpp</sub> (A)	8,1	8,2	8,2	8,3	8,3	8,4	8,4	8,5
Open circuit voltage V <sub>oc</sub> (V)	37,1	37,5	37,7	38,0	38,3	38,6	38,9	39,1
Short circuit current I <sub>sc</sub> (I)	8,6	8,7	8,8	8,8	8,9	8,9	9,0	9,0
Cell efficiency (%)	16,4	16,8	17,1	17,4	17,8	18,1	18,4	18,7
Fill factor	0,75	0,75	0,75	0,76	0,77	0,78	0,78	0,79
Power output tolerance P <sub>mpp</sub> (%)	±5							

### Values at NOCT:

NOCT = 47,5°C

The NOCT (nominal operating temperature) is the cell temperature at an irradiation of 800W/m<sup>2</sup>, at an environment temperature of 20°C and a wind speed of 1m/s.

Irradiance level 800W/m<sup>2</sup>, spectrum AM 1,5, wind velocity 1m/s, T<sub>amb</sub> 20°C.

Module type	240Wp	250Wp	260Wp	270Wp
P <sub>mpp</sub> (Wp)	173,6	179,6	186,2	-
I <sub>mpp</sub> (A)	6,48	6,52	6,71	-

### Normal operating conditions:

Under normal conditions, a photovoltaic module is likely to experience conditions that produce more current and/or voltage than rated at standard test conditions. Accordingly, the values of Short Circuit Current I<sub>sc</sub> and Open Circuit Voltage V<sub>oc</sub> marked on this module should be multiplied by a factor of 1,25 when determining component voltage ratings, conductor current ratings, fuse size, and size of controls connected to the PV output.



## Underwriters Laboratories Information (U.S. and Canada only)

Under normal conditions, a photovoltaic module is likely to experience conditions that produce more current and/or voltage than reported at Standard Test Conditions. Accordingly, the values of I<sub>sc</sub> and V<sub>oc</sub> marked on this module should be multiplied by a factor of 1.25 when determining component voltage ratings, conductor amp cities, fuse sizes, and size of controls connected to the PV output.

Refer to section 690-8 of the National Electric Code (NEC) for an additional multiplying factor of 125% (80% derating) which may be applicable.

## Maintenance

If the array has a sufficient tilt, i.e. minimum 18°, it will generally not be necessary to clean the modules - the rain will usually do so. Dirt on the module surfaces causes cell shading and can lead to reduced electrical output. If necessary, clean the modules with plenty of water (using a hose) - without cleaning agents - with a soft clearing implement (sponge). Under no circumstances should dirt be scraped or rubbed off the modules when dry, as this can cause micro-scratches on the surface of the modules and reduce the transparency of the module glass. The system should be inspected regularly and the following items checked:

- All fastenings and fixing are secure, tight and free of corrosion.
- All electrical connections are secure and tight and clean and free of corrosion.
- The mechanical integrity of the cables.
- The continuity of equipotential bonding.

## Liability limitation

Windon AB accepts no liability for the usability and functionality of its solar modules if the instructions in this guide are not followed. Since compliance with this guide and the conditions and methods of installation, operation, use and maintenance of the modules are not checked or monitored by Windon AB, Windon AB accepts no liability for damage arising from improper use or incorrect installation, operation, use or maintenance. This does not apply to damages due to a module fault, in cases of loss of life, bodily injury or damage to health or in the event of a grossly negligent breach of obligations on the part of Windon AB and/or in the event of an intentional or grossly negligent breach of obligations by a legal representative or vicarious agent.

## Disposal considerations

This product must be disposed of in accordance with all relevant local, state and federal laws and regulations. It is the responsibility of the customer to ensure that this product is disposed of properly. Please contact your local Windon AB representative concerning the proper disposal of this product.



Windon AB  
www.windon.se

July 2013, revision 07

### Revision history (W refer to Windon AB)

July 2013, rev 07W

- Windon ground mounting structure added.
- STC values added for modules up to 275Wp.
- NOCT for 240-260Wp added
- Temperature ratings updated according to latest measurement at TÜV.

October 2012, rev 06W

- Release of Installation instruction for Windon AB.

Windon AB reserved the right to change specifications without notice.